

USER MANUAL

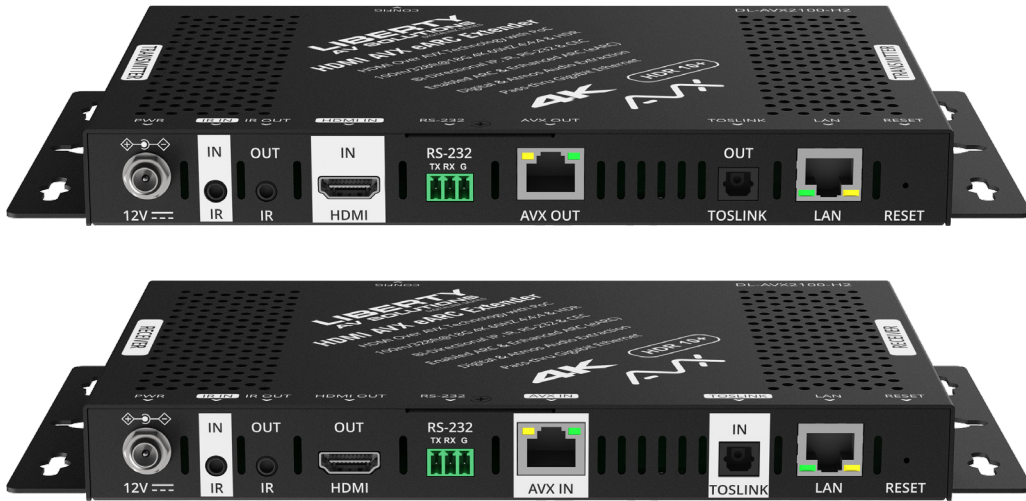

HDMI2.0 Extender Set with eARC DL-AVX2100-H2

PRODUCT OVERVIEW

This AVX HDMI2.0 eARC extender kit supports HDR format Dolby Vision up to 4K@60 and full eARC capabilities up to Dolby Atmos. It supports both static and dynamic HDR formats up to 4K@60Hz, including Dolby Vision. It also supports full eARC function and is backward compatible with 5.1CH ARC.

On the control end, it features bi-directional IR, RS232, 1GbE ethernet extensions, and S/PDIF pass-through between the eARC transmitter and receiver. With 1-way PoE built-in from the eARC transmitter to receiver, only one power adapter is needed to power up the extender kit.

PACKAGE CONTENTS



(x1) Transmitter



(x1) Receiver

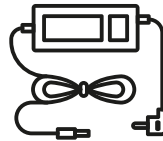

(x1) DC 12V
Power Adapter

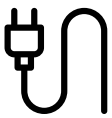

(x1) AC Power
Cord with US Pins

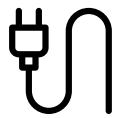

(x1) AC Power
Cord with UK Pins

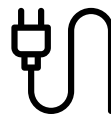

(x1) AC Power
Cord with EU Pins

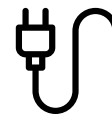

(x1) AC Power
Cord with AU Pins

(x1) IR Emitter

(x1) Broadband IR
Receiver (30-50 KHz)

(x2) 3.5mm 3-Pin
Phoenix Connector

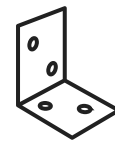

(x4) Mounting
Brackets (with Screws)

PRODUCT BREAKDOWN

Transmitter

Front Panel

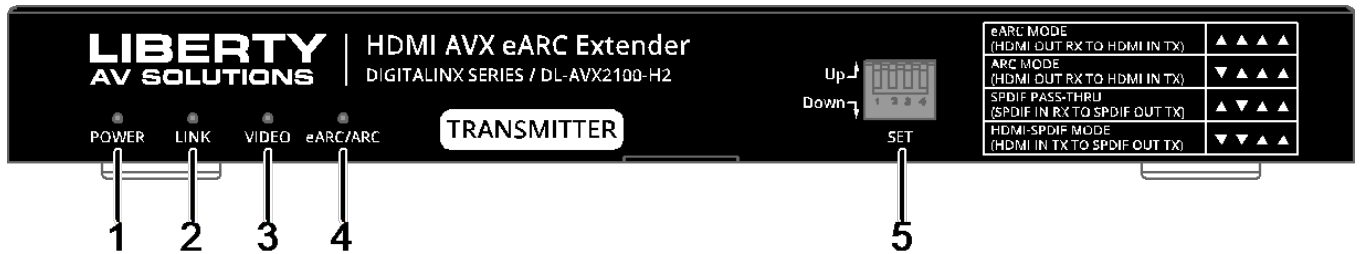

1. Power LED
2. Link LED
3. Video LED
4. eARC/ARC LED
5. SET

Rear Panel

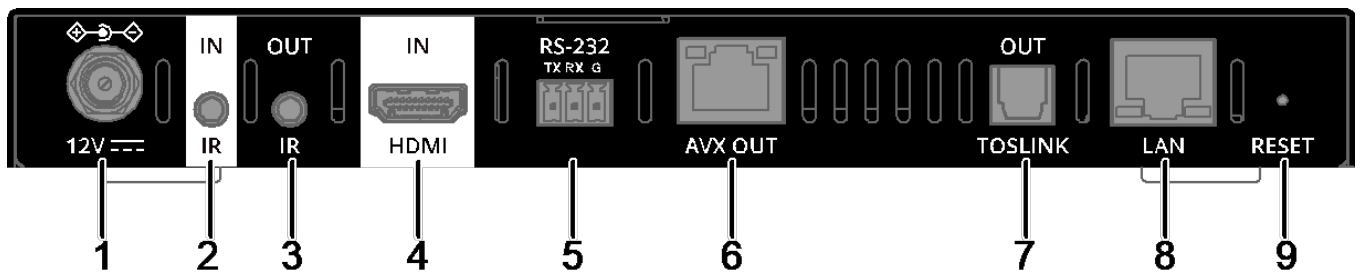

1. DC 12V
2. IR IN
3. IR OUT
4. HDMI IN
5. RS232
6. AVX OUT
7. TOSLINK OUT
8. LAN
9. RESET

Receiver

Front Panel

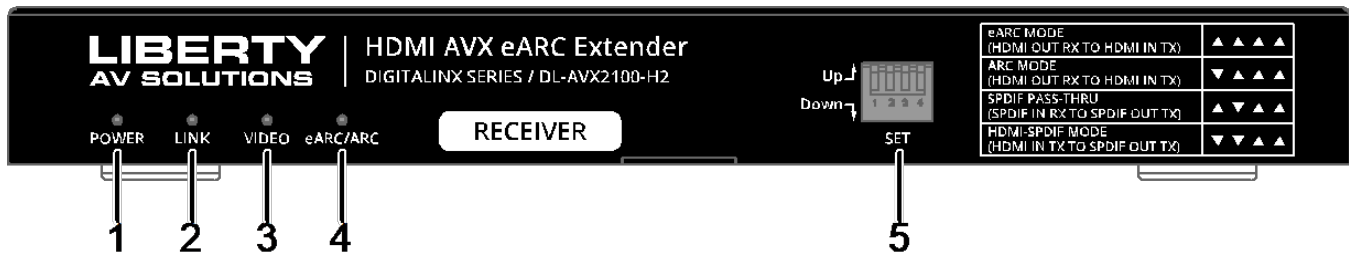

1. Power LED
2. Link LED
3. Video LED
4. eARC/ARC LED
5. SET

Rear Panel

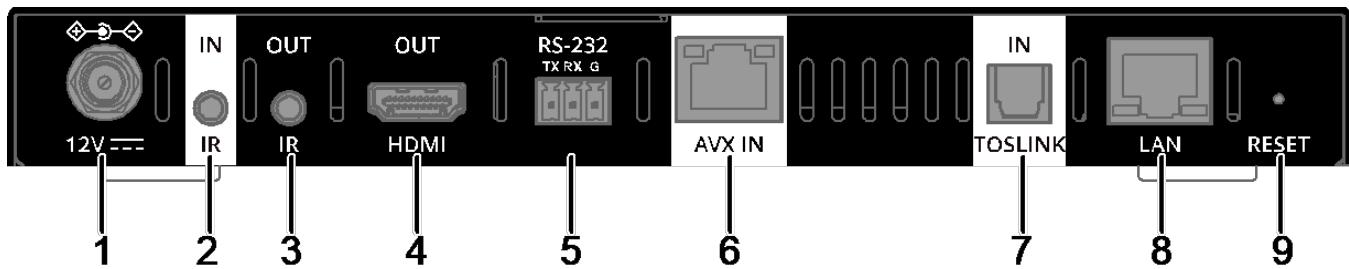

1. For Future Use
2. IR IN
3. IR OUT
4. HDMI OUT
5. RS232
6. AVX IN
7. TOSLINK IN
8. LAN
9. RESET

INSTALLATION AND WIRING

Installation

Warnings:

- Before wiring, disconnect the power from the device.
- During wiring, connect and disconnect the cables gently.

Steps to install the device:

1. Attach the installation bracket to the enclosure using the screws provided in the package separately.
2. The bracket is attached to the enclosure as shown.

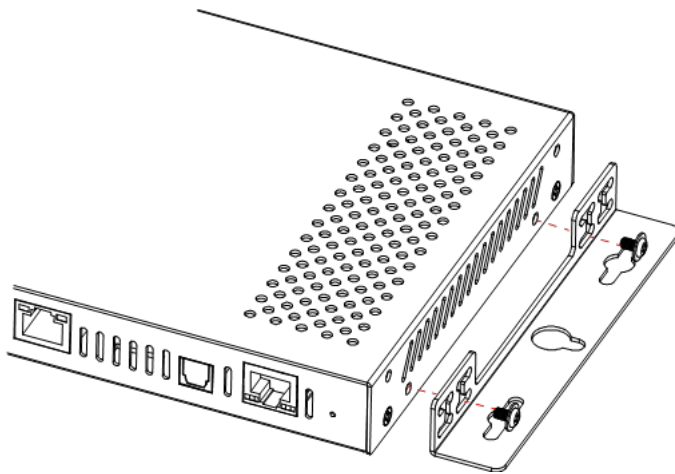

3. Repeat the steps from 1 to 2 for the other side of the unit.
4. Attach the brackets to the surface you want to hold the unit against using the screws (provided by others).
5. Repeat the steps from 1 to 4 to install the receiver.

Wiring

Warnings:

- Before wiring, disconnect the power from all devices.
- During wiring, connect and disconnect the cables gently.

Wiring 1: eARC/ARC mode

Note: When you want to configure eARC/ARC channel feed by TV: Ensure the connected AV receiver and TV support eARC/ARC function and the TV's CEC function should be set to enable.

1. Set the DIP switches of transmitter and receiver to eARC/ARC mode (See "DIP Switch Settings" section).
2. Connect an AV receiver to HDMI IN port of the transmitter.
3. Connect a display such as a TV to HDMI OUT port of the receiver.
4. Connect the AVX OUT port of transmitter to AVX IN port of the receiver.
5. Set CEC function of the TV to on.
6. Switch the AV receiver to eARC/ARC channel.
7. Connect the provided power adapter to the transmitter. **Note- Power port of the receiver is for future use and is covered with tape. Device must be powered on the transmitter side only. Please do not remove the tape as this port currently does not function.
8. Power on all attached devices. The audio signal of TV through HDMI OUT port will be transmitted to

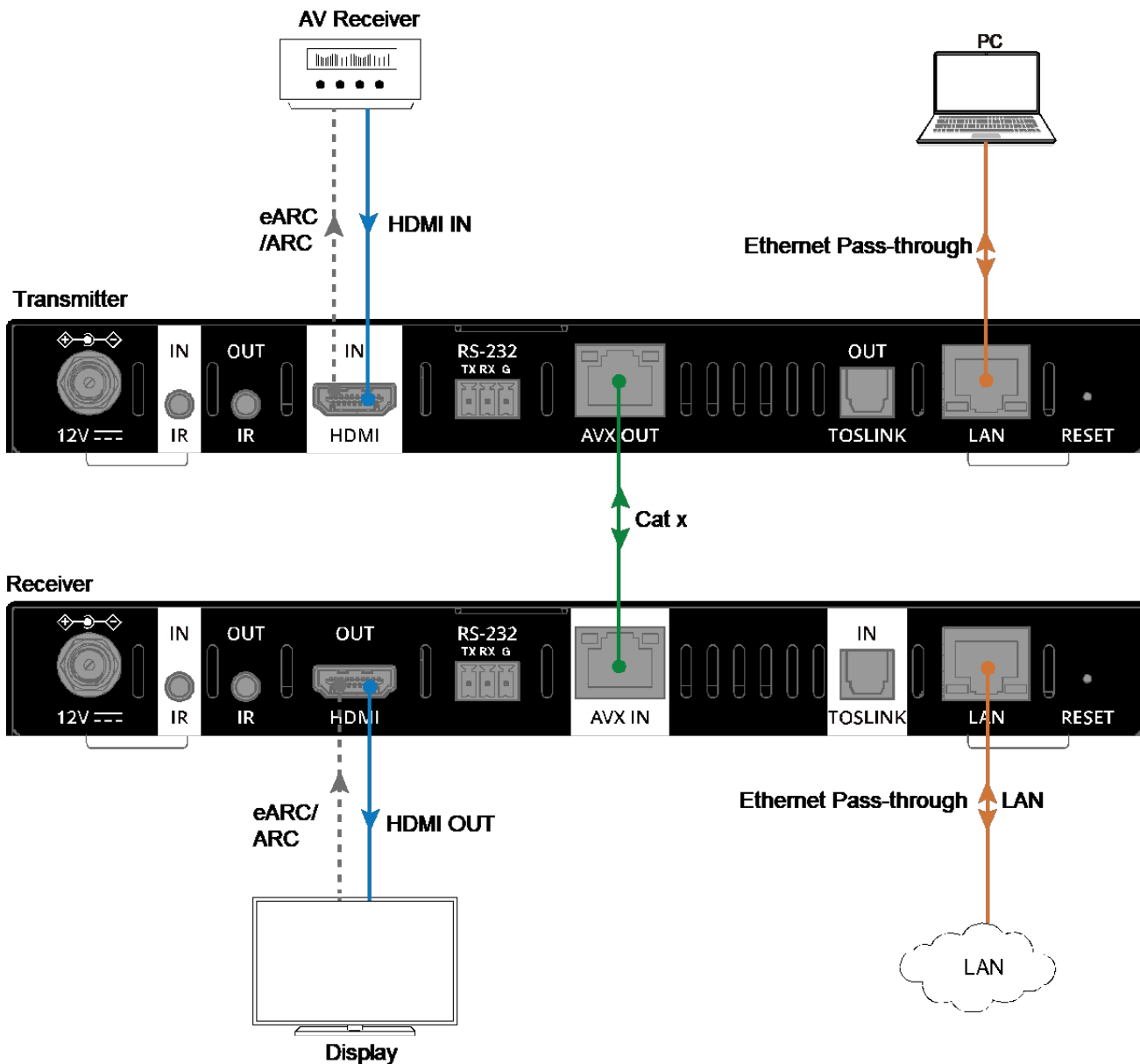

Wiring 2: S/PDIF Pass-through mode

1. Set the DIP switches of transmitter and receiver to SPDIF mode (See "DIP Switch Settings" section).
2. Connect an audio receiver to the TOSLINK OUT port of transmitter.
3. Connect an audio source to TOSLINK IN port of receiver.
4. Connect AVX OUT port of the transmitter to AVX IN port of the receiver.
5. Connect the provided power adapter to the transmitter. **Note- Power port of the receiver is for future use and is covered with tape. Device must be powered on the transmitter side only. Please do not remove the tape as this port currently does not function.
6. Power on all attached devices. Audio signal from TOSLINK IN port will be transmitted to TOSLINK OUT port. (See Figure 2)

Note: When set the DIP Switches to Audio de-embedding mode, the audio receiver connected to

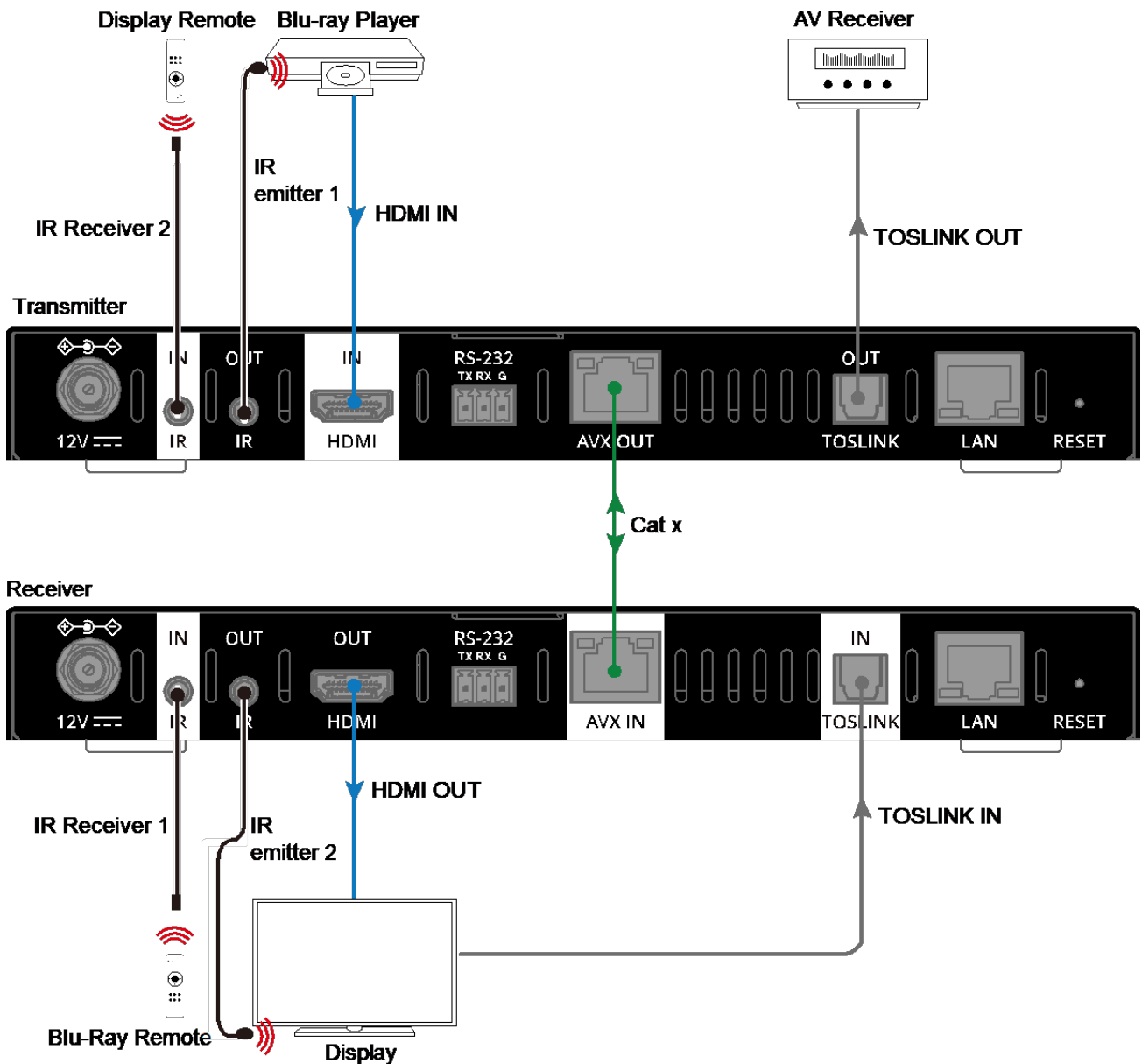

For additional wiring:

- Bi-directional IR pass-through: Connect the provided IR receiver to IR IN port of the transmitter/receiver, and connect the provided IR emitter to IR OUT port of the receiver/transmitter. You can control the HDMI source at receiver side or control the display at transmitter side. (See Figure 2)
- Bi-directional Ethernet pass-through: Connect the LAN port of the transmitter/receiver to the local area network, and connect the LAN port of the receiver/transmitter to a PC. The PC can be connected the local area network. (See Figure 1)
- Bi-directional RS232 pass-through: Connect RS232 enabled devices such as PC to RS232 ports of the transmitter and receiver. (See "RS232 Pass-Through" section)

DIP SWITCH SETTINGS

Using DIP Switches on front panel of the transmitter and receiver to set the kit to eARC mode, ARC mode, S/PDIF pass-through and Audio De-embedding mode according to the audio modes needed.

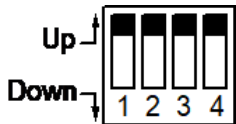

Please refer to the following table to set:

Transmitter				Receiver				Function
1	2	3	4	1	2	3	4	
Up	Up	Up	Up	Up	Up	Up	Up	eARC mode (default)
Down	Up	Up	Up	Down	Up	Up	Up	ARC mode
Up	Down	Up	Up	Up	Down	Up	Up	S/PDIF Pass-through mode
Down	Down	Up	Up	Down	Down	Up	Up	Audio De-embedding mode

RS232 PASS-THROUGH

RS232 ports can be used for bi-directional RS232 signal pass-through between the transmitter and receiver.

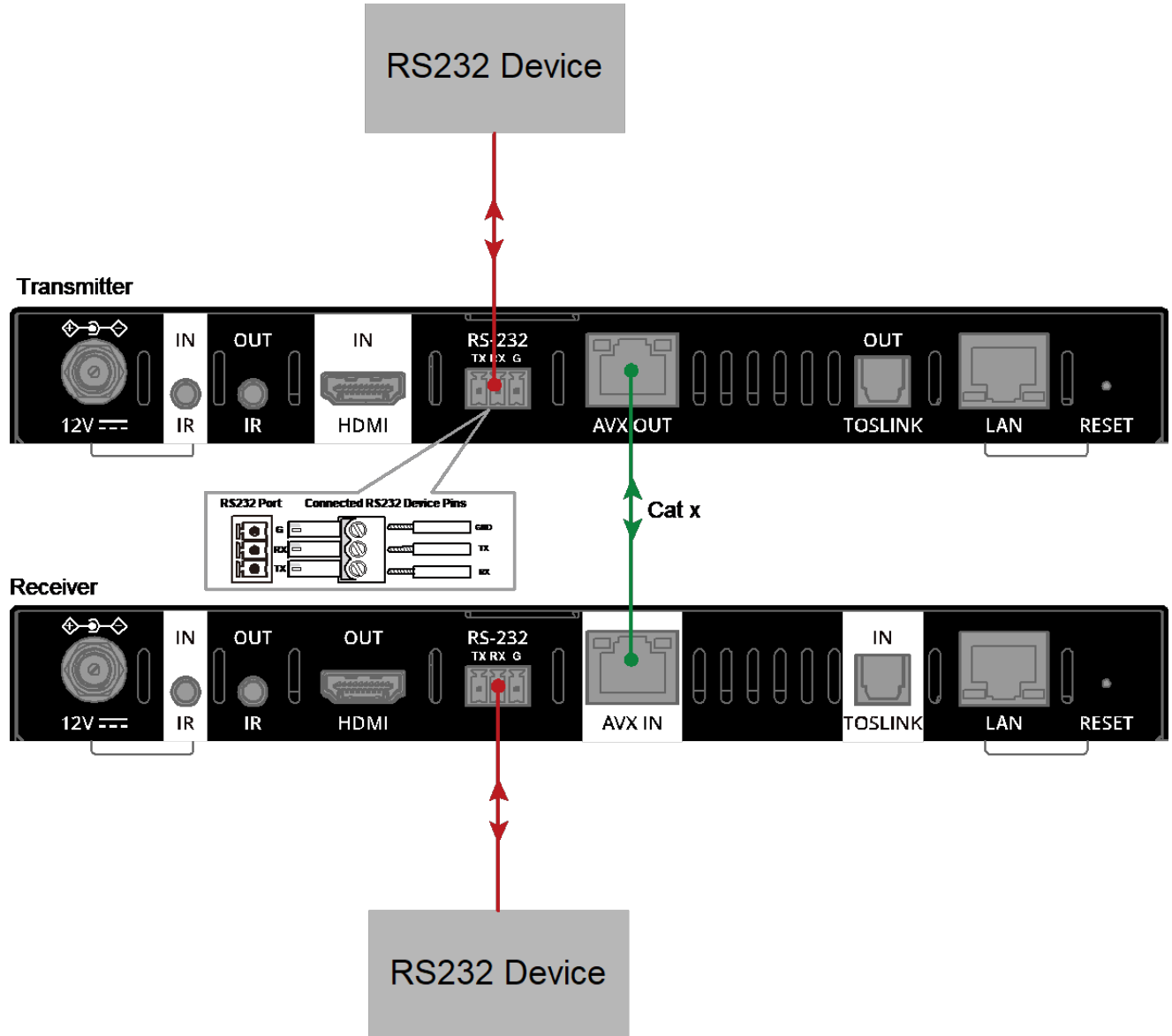

TECHNICAL SPECIFICATIONS

Technical	
Input/Output Port	<p>Transmitter: 1 x HDMI IN, 1 x AVX OUT, 1 x TOSLINK OUT, 1 x IR IN, 1 x IR OUT, 1 x RS232, 1 x LAN, 1 x DC 12V IN</p> <p>Receiver: 1 x HDMI OUT, 1 x AVX IN, 1 x TOSLINK IN, 1 x IR IN, 1 x IR OUT, 1 x RS232, 1 x LAN, 1 x DC 12V IN</p>
Input/Output Signal Type	HDMI with 4K@60Hz 4:4:4 8bit, HDCP 2.3 compliant
Input/Output Resolution Supported	<p>VESA: 800 x 600⁸, 1024 x 768⁸, 1280 x 768⁸, 1280 x 800⁸, 1280 x 960⁸, 1280 x 1024⁸, 1360 x 768⁸, 1366 x 768⁸, 1440 x 900⁸, 1600 x 900⁸, 1600 x 1200⁸, 1680 x 1050⁸, 1920 x 1200⁸, 2048 x 1152⁸,</p> <p>SMPT E: 1280 x 720P^{6,7,8}, 1920 x 1080P^{6,7,8}, 3840 x 2160^{2,3,5,6,8}, 4096 x 2160^{2,3,5,6,8}</p> <p>1 = at 23.98 Hz, 2 = at 24 Hz, 3 = at 25 Hz, 4 = at 29.97 Hz, 5 = at 30 Hz, 6 = at 50 Hz, 7 = at 59.94 Hz, 8 = at 60 Hz</p> <p>Note: The extender kit supports resolution up to 4K@60 in Dolby Vision low latency mode. For Dolby Vision standard mode, it supports resolution up to 4K@30.</p>
HDR	HDR 10, HDR 10+, HLG
Maximum Data Rate	18 Gbps
Maximum Pixel Clock	600 MHz
Audio Format Supported	<p>HDMI: Supports all HDMI 2.0 formats including multi-channel PCM, Dolby True-HD and DTS-HD master audio;</p> <p>SPDIF: Supports 5.1-ch compressed audio (such as Dolby Digital, DTS 5.1, and Dolby Digital Plus), and 2.0-ch uncompressed PCM audio;</p> <p>ARC Mode: Supports 5.1-ch compressed audio (such as Dolby Digital, DTS 5.1, and Dolby Digital Plus), and 2.0-ch uncompressed PCM audio;</p> <p>eARC mode: Up to 8-ch L-PCM of 192kHz audio; Supports encoded audio formats, such as Dolby Atmos and DTS-X.</p>

General	
Operating Temperature	0°C to 45°C (32°F to 113°F)
Storage Temperature	-20°C to 70°C (-4°F to 158°F)
Humidity	10% to 90%, non-condensing
ESD Protection	Human-body Model: ±8kV (Air-gap discharge)/±4kV (Contact discharge)
Power Supply	DC 12V 3A
Power Consumption (Maximum)	21.8W
Device Dimension (W x H x D)	215mm x 25mm x 140.2mm/ 8.46" x 0.98" x 5.52" each for TX/RX
Product Weight	Transmitter:0.77kg/1.70lb; Receiver: 0.78kg/1.72lb

TRANSMISSION DISTANCE

Note: T568B straight-through Category cable is recommended.

Cable Type	Range	Supported Video
Cat 5e/6	80m/263ft	4K@60Hz 4:4:4 24bpp
Cat 6a/7	100m/330ft	4K@60Hz 4:2:2 4K@60Hz 4:2:0 30/36bpp 4K@30Hz 4:4:4 30/36bpp
HDMI	Input/Output: 15m/50ft	1080P@60Hz 4K@30Hz 4:4:4 24bpp
	Input/Output: 5m/16ft	4K@60Hz 4:4:4 24bpp

Thank you for your purchase.

For Technical Support please call our
toll-free number at 800-530-8998
or email us at supportlibav@libav.com

LIBERTY
AV SOLUTIONS

www.libav.com 800-530-8998